

LUBRICATE ALL SEALS WITH CLEAN HYDRAULIC OIL PRIOR TO ASSEMBLY.
DO NOT USE SILICONE BASED LUBRICANTS.

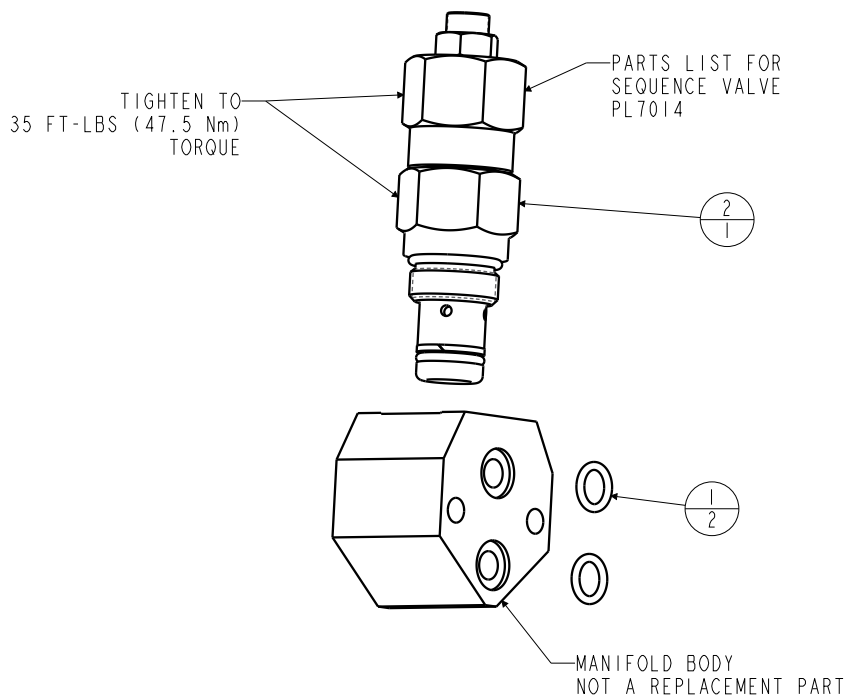

2	1	70443002	ASSY, VLV, SEQ, CM
1	2	39050042	O-RING, (-011)
No.	QTY	PART No.	DESCRIPTION

PARTS LIST



VEKTEK, INC.
1334 E. SIXTH AVE. P.O. BOX 625
EMPORIA, KS. 66801 U.S.A.

WEIGHT .95 LBS

A	5076	RELEASE	JDW	04/18/23
REV	IN ACCORDANCE WITH ECN	EFFECTIVE DATE	REVISED BY	DATE
DRW BY: JDW	DRAWING STATUS: Released			
DATE: 04/18/23	PRODUCTION APPROVED FOR RELEASED STATUS ONLY			

ASSEMBLIES AFFECTED
70441002

PARTS LIST, ASSY, VALVE, SEQ, MM

SIZE
A PL7037

REV
A

SHEET 1 OF 1

FORM FEG035_PL_ASIZE, REV. B